



# ERCO IL 635.2



3,5 t



**Sollevatore elettroidraulico a doppio cilindro e sovrastruttura a due piattaforme**



*Electro-hydraulic twin-ram lift and superstructure with two flat lifting supports*





### GRUPPO POMPA IDRAULICA CON MOTORE IMMERSO IN OLIO HYDRAULIC PUMP UNIT WITH IMMERSED MOTOR IN OIL

- Motore immerso in olio, **protetto da umidità** / condensa nella cassetta
- **Salita e discesa non dipendenti dal peso sollevato** grazie alla valvola di controllo del flusso
- Due valvole per un **alto grado di sicurezza**
- *Motor immersed in oil, i.e. **protected against humidity** / condensation in the cassette*
- ***Lifting and lowering not depending on weight** because of the flow control valve*
- *Two valves for **high degree of safety***

### CILINDRI INVERSI - INVERTED CYLINDERS

- **Guarnizioni interne e anelli di guida**, ben **protette dagli agenti esterni**
- Tubo del cilindro e pistone ingranaggi cromati a fondo (copertura cromata min. 30 µm) per la **massima protezione dalla corrosione e scorrimento facilitato**
- **Lunga durata** della tenuta del pistone
- *Internal sealings and guiding belts, thus well **protected against outside influences***
- *Hard-chrome plated cylinder tube and gear piston (min. 30 µm chrome covering) for a **maximum corrosion protection and easy gliding***
- ***Long lifetime** of piston sealing*



### DISPOSITIVI DI SINCRONIZZAZIONE E SICUREZZA SYNCHRONIZATION AND SAFETY DEVICES

- Sistema **sincronizzazione a leve collegate**
- Sistema di **controllo sicuro dell'altezza** con sensore a trasmettitore di impulsi
- ***Synchronization** system by means of **connected levers***
- ***Safe height control system**: sensor with impulse transmitter*

# ERCO IL 635.2

## UNITÀ DI CONTROLLO A PULSANTI PROGRAMMABILE - PROGRAMMABLE PUSH BUTTON CONTROL UNIT

- Discesa di emergenza pneumatica **di serie**
- **Max. altezza di sollevamento e segnale di allarme** (arresto CE) liberamente **programmabili**, per finecorsa meccanico.
- **Indicazione di errore** tramite sequenza di allarmi in caso di disfunzione
- *Pneumatic emergency lowering for power-off lowering, as **standard***
- ***Max. lifting height and alarm signal** (CE-stop) freely **programmable**, for mechanical end stop*
- ***Error indication** via alarm sequence in case of disfunction*



## CASSETTA IN ACCIAIO - STEEL CASSETTES

- Le cassette in acciaio vengono consegnate con **certificazione di impermeabilità**
- Pre-montaggio dell'unità idraulica (a richiesta)

- *Steel cassettes are delivered with **waterproof certification***
- *Pre-fitting of the hydraulic unit (optional)*



## SOVRASTRUTTURA - SUPERSTRUCTURE

- **Due supporti di sollevamento regolabili** in lunghezza
- **Appoggi rivestiti in gomma**, antiscivolo.
- Zincatura e verniciatura RAL 9006
- ***Two lifting supports, lengthwise adjustable***
- *Rubber-coated, **non-skid pads***
- *Zinc coated and painted RAL 9006*



## SUPPORTO XY - XY-PADS

- **Supporti XY (a richiesta)** realizzati in una speciale **lega di alluminio**, hanno **piastre in acciaio inossidabile** e offrono un campo di applicazione più ampio.
- ***XY-pads available (optional)** are made of a **special aluminium alloy**, have **stainless steel plates** and offer wider field of application.*

**DATI TECNICI - TECHNICAL DATA**

Capacità di sollevamento	Lifting capacity,	3.500 kg
Lunghezza corsa	Stroke length	1.950 mm
Altezza di lavoro	Working height	2.015 mm + Tamponi in gomma / Rubber blocks
Diametro dei cilindri	Cylinder diameter	2 x 123 mm
Tempo di salita / discesa	Lifting / lowering time	~ 30 sec.
Profondità della fondazione	Foundation depth	2.625 mm
Unità pompa	Pump unit	3,0 kW
Olio idraulico	Hydraulic oil	10 l
Tensione di alimentazione	Supply voltage	230/400 V / 50 Hz / 16 A

**ACCESSORI OBBLIGATORI  
COMPULSORY ACCESSORIES**



Olio idraulico 10 l.  
Oil filling 10 ltr.



Set di cavi 10 m.  
Set of cables 10 m.



Olio idraulico 17 l.  
Oil filling 17 ltr.

**ACCESSORI RACCOMANDATI  
RECOMMENDED ACCESSORIES**



Set di tamponi in gomma 40 mm, 120x120xØ100 (4 pz.)  
Set of Rubber blocks 40 mm, 120x120xØ100 (4 pcs)



Supporti XY realizzati in una speciale lega di alluminio  
XY-pads available are made of a special aluminium alloy

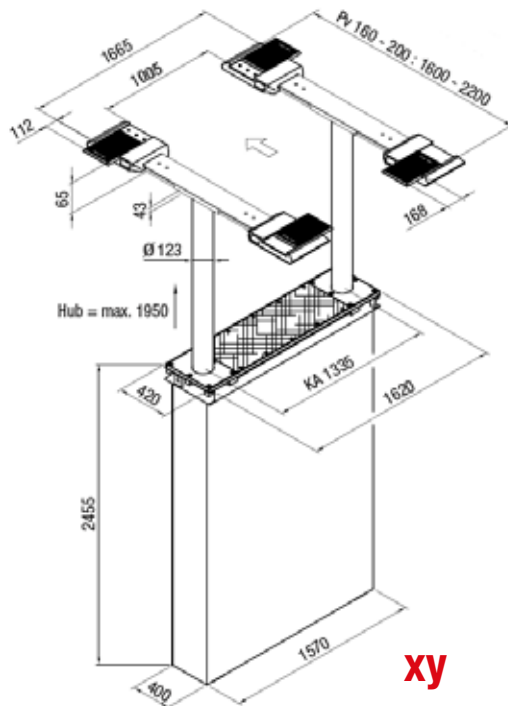
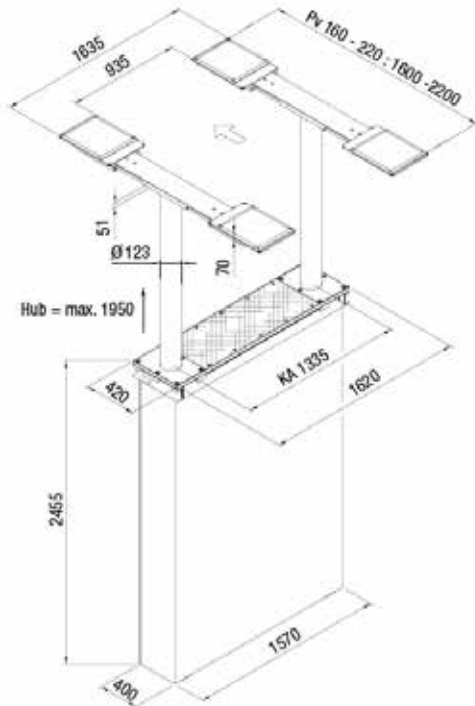

Fotografie, caratteristiche ed i dati tecnici non sono vincolanti, possono subire modifiche senza preavviso.  
The manufacturer reserves the right to modify the features of its products at any time.  
Cod. **DPC6001092B** 01/2021

Per aiutare il pianeta ottimizzando il consumo di carta, i nostri cataloghi sono consultabili sul sito [www.corghi.com](http://www.corghi.com). Una stampa responsabile aiuta a preservare l'ambiente.  
To protect the planet and reduce paper usage, our catalogues are viewable online at the website [www.corghi.com](http://www.corghi.com).  
Printing responsibly contributes to saving the environment.



NEXION SPA - [www.corghi.com](http://www.corghi.com) - [info@corghi.com](mailto:info@corghi.com)

