

CS44



Stallonatore/Smontagomme elettroidraulico

Il CS44 è un attrezzo specifico per ruote da competizione, dove in tempi ristretti occorre erogare il massimo delle prestazioni. Di costruzione solida, la macchina lavora tenendo la

ruota in posizione orizzontale per la stallonatura, per il montaggio e per lo smontaggio. I comandi del tipo "ad uomo presente" sono eseguiti dall'operatore mediante pedaliera.



Electrohydraulic bead breaker/tyre changer

The CS44 is specifically designed for use in the pit, for racing wheels, where the maximum performance has to be provided in the shortest time. Ruggedly built, the machine works with the tyre kept

in the horizontal position for bead breaking, mounting and demounting. The commands, which function on the "dead man" principle, are given by the operator by means of a pedal control unit.



Détalonneur/démonte pneus electro-hydraulique

Le CS44 est un outil spécifique de stand pour les roues racing, où en un temps très brefs, il faut offrir le maximum de performances.

De construction solide, l'appareil fonctionne en tenant la roue en position horizontale pour le détalonnage, pour le montage et pour le démontage. Les commandes du type "à homme présent" sont effectuées par l'opérateur par l'intermédiaire du pédalier.



Elektrohydraulische Reifenabdruck-/Reifenmontiermaschine

CS44 is eine spezielle Ausrüstung für Rennreifen, die u.a. in den Boxen eingesetzt wird, wo in kürzester Zeit Höchstleistungen erbracht werden müssen.

Die in solider Bauweise gearbeitete Maschine hält das Rad bei der Arbeit in horizontaler Position, um die Wulstabdrückung, die Montage und die Demontage durchzuführen. Die „Totmann-Steuerung“ wird vom Bedienungspersonal mittels Pedal betätigt.



Destalonador/desmontadora de neumáticos electrohidráulico

CS44 es un equipo específico de box para ruedas racing, en el que en tiempos limitados se debe brindar el máximo de las prestaciones.

De sólida fabricación, la máquina trabaja manteniendo la rueda en posición horizontal para efectuar la destalonadura, el montaje y el desmontaje. Los mandos del tipo "operador presente" son ejecutados por el operador mediante pedalera.

This product has been certified by:

BRIDGESTONE



CORGI



Operazione di stallonatura
 Bead breaking operations
 Opération de détalonnage
 Abdrückungsvorgang
 Operación de destalonadura

Operazione di smontaggio
 Stripping operations
 Opération de démontage
 Demontagevorgang
 Operación de desarme

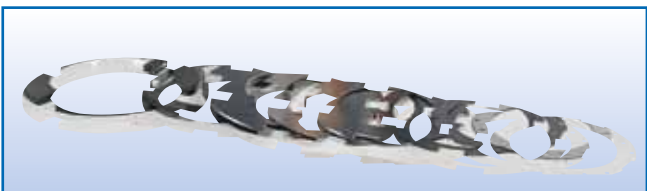

Kit accessori a richiesta per operare su diametri fino a 20"
 Optional accessories kit to work up to 20"Ø
 Jeu d'accessoires sur demande pour travailler avec diamètre jusqu'à 20"
 Satz von Zubehörteile auf Anfrage zum Einsatz bei Durchmesser bis zu 20"
 kit de accesorios bajo pedido para trabajar sobre diámetros hasta 20"

Bloccaggio rapido e sicuro
 Safe and quick locking
 blocage rapide et en sécurité
 Schnelle und sichere Festspannung
 Bloqueo rapido y seguro



Operazione di montaggio
 Mounting operations
 Opération de montage
 Montagevorgang
 Operación de montaje



Pedaliera con comandi a "uomo presente"
 "Dead man" pedal control unit
 Pédalier avec commande à "homme présent"
 "Totmann-Steuerung" mittels Pedal
 Mando a pedal a operador presente



Stallonatore idraulico a corsa lunga
 Long stroke hydraulic bead breaker
 Détalonneur hydraulique à course longue
 Langhubiger, hydraulischer Abdrücker
 Destalonador hidráulico de larga carrera



Dati tecnici

Bloccaggio autocentrante	da 13" a 20"
Forza stallonatrice	6000 kg
Diametro cerchione	da 13" ÷ 20"
Larghezza max. copertura	20"
Pressione di esercizio	110 bar
Peso macchina	186 kg
Peso macchina + centralina	228 kg
Motore monofase	230V 1ph 50Hz 1,5 kW



Technical data

Turntable clamping	from 13" to 20"
Bead breaking force	6000 kg
Rim diameter	from 13" to 20"
Max. tyre width	20"
Operating pressure	110 bar
Weight of machine	186 kg
Weight of machine + power unit	228 kg
Single-phase motor	230V 1ph 50Hz 1.5 kW



Données techniques

Blocage du mandrin	de 13" ÷ 20"
Force de détalonnage	6000 kg
Diamètre de la jante	de 13" ÷ 20"
Largeur maxi. de la couverture	20"
Pression de service	110 bar
Poids de l'appareil	186 kg
Poids de l'appareil + distributeur	228 kg
Moteur monophasé	230V 1ph 50Hz 1,5 kW



Technische Daten

Verriegelung Spannfutter	zwischen 13" und 20"
Abdrückkraft	6000 kg
Felgendurchmesser	zwischen 13" und 20"
Max. Reifenbreite	20"
Betriebsdruck	110 bar
Maschinengewicht	186 kg
Gewicht Maschine und Bedienungssäule	228 kg
Einphasiger Motor	230V 1ph 50Hz 1,5 kW



Datos técnicos

Bloqueo autocentrante	entre 13" y 20"
Fuerza destalonadora	6000 kg
Diámetro llanta	entre 13" y 20"
Anchira máx. cubierta	20"
Presión de servicio	110 bar
Peso máquina	186 kg
Peso máquina + centralita	228 kg
Motor monofásico	230V 1ph 50 Hz 1,5 kW

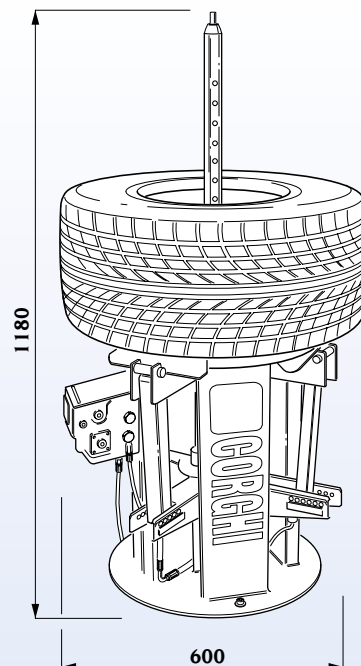

L'azienda si riserva di modificare le caratteristiche dei prodotti in qualsiasi momento.

Corghi reserves the right to modify the technical specification of their products at any time without prior notice.

La société se réserve le droit de modifier les caractéristiques de ses produits à tout moment.

Der Hersteller sich das Recht vor, die Produktmerkmale jederzeit zu ändern.

La empresa se reserva el derecho de modificar las características de los productos en cualquier momento.